

ICC Evaluation Service, Inc.
www.icc-es.org

Business/Regional Office ■ 5360 Workman Mill Road, Whittier, California 90601 ■ (562) 699-0543
Regional Office ■ 900 Montclair Road, Suite A, Birmingham, Alabama 35213 ■ (205) 599-9800
Regional Office ■ 4051 West Flossmoor Road, Country Club Hills, Illinois 60478 ■ (708) 799-2305

DIVISION: 06—WOOD AND PLASTICS
Section: 06120—Structural Panels

REPORT HOLDER:

AGRIBOARD INDUSTRIES, A RYAN DEVELOPMENT COMPANY, L.C.
100 INDUSTRIAL DRIVE
POST OFFICE BOX 151
ELECTRA, TEXAS 76360

EVALUATION SUBJECT:

AGRIBOARD PANEL BUILDING SYSTEMS

1.0 EVALUATION SCOPE

Compliance with the following codes:

- 2003 *International Building Code*® (IBC)
- 2003 *International Residential Code*® (IRC)

Properties evaluated:

- Structural
- Weather-resistance
- Fire-resistance

2.0 USES

Agriboard Panel Building Systems are used as exterior and interior load-bearing and nonload-bearing wall panels. The panels shall be limited to use in Type V construction and to Seismic Design Categories A, B and C.

3.0 DESCRIPTION

3.1 Agriboard Panels:

The Agriboard Panel Building System is a factory-assembled sandwich panel consisting of oriented strand board (OSB) facings laminated to both sides of a kraft-linerboard-wrapped compressed straw core, with structural composite lumber panel perimeter members. The panels have a Class B rating when tested in accordance with ASTM E 84 and have 1-hour and 2-hour fire-resistance ratings, depending on panel thickness, when tested in accordance with ASTM E 119. The panels are manufactured with 4³/₈- and 7⁷/₈-inch (111 or 200 mm) thicknesses and in sizes up to 8 feet (2438 mm) by 24 feet (7315 mm) wide. The structural composite lumber has keyways on vertical edges to accept field-installed splines, and on horizontal edges to accept field-installed keys. See Figures 1 through 3 for field installation details.

3.2 Materials:

3.2.1 Core: The core of the panels is one or two layers of a compressed agricultural fiber board (Agri-Core™). The CAF

board has a thickness of 3¹/₂ inches (89 mm) and consists of compressed wheat straw with a kraft linerboard laminated to the faces and edges. End cap paper is mechanically attached to the ends of the Agri-Core™. The nominal density of the compressed wheat straw is 14 pcf (224 kg/m³).

3.2.2 Facing: Panel facing material is 7¹/₁₆-inch-thick (11.1 mm) OSB rated sheathing classified as Exposure 1, having a span rating of 24/16 and complying with the U.S. Department of Commerce standard PS-2.

3.2.3 Panel Perimeter Members (Profile Boards): The structural composite lumber is factory-installed on the edges and ends of the panels and is 1.5 E grade TimberStrand laminated strand lumber (LSL) manufactured by Trus Joist, A Weyerhaeuser Business, and recognized in ICC-ES evaluation report ER-4979. These members are 3¹/₂ inches (89 mm) wide and have a thickness to match the panel core thickness [either 3¹/₂ or 7 inches (89 or 178 mm)]. The keyway in the perimeter members of the 4³/₈-inch-thick (111 mm) panels is 1³/₄ inches (45 mm) wide and 1³/₄ inches (45 mm) deep. The keyway in the perimeter members of the 7⁷/₈-inch-thick (200 mm) panels is 3¹/₂ inches (89 mm) wide and 1³/₄ inches (44.5 mm) deep.

3.2.4 Adhesives:

3.2.4.1 Laminating Adhesive: The adhesive used at the panel manufacturing facility to laminate the OSB to the panel perimeter members, laminate the OSB to the panel core, laminate two layers of Agri-Core™ together to form panels with a 7-inch-thick (178 mm) core and to laminate the kraft linerboard to the compressed straw is a Type II, Class 2, adhesive specified in the approved quality control manual. The adhesive is applied in accordance with the approved quality control manual.

3.2.4.2 Key and Spline to Perimeter Frame Adhesive: The adhesive used at the jobsite to attach the keys and splines to the perimeter frame of the panels is Ashland Specialty Chemical Company ISOGRIP SP3030D recognized in ICC-ES evaluation report ER-5715. The adhesive shall be applied in accordance with Section 4.2.1 of this report.

3.2.5 Fasteners:

3.2.5.1 Facer Attachment to Perimeter Members: In addition to adhesive attachment, the OSB panel facings are factory-attached to the LSL panel perimeter members with No. 16 gage galvanized staples having a 1¹/₂-inch (12.7 mm) crown width and 7⁷/₈-inch (22 mm) length. The staples shall be spaced at 6 inches (152 mm) on center.

3.2.5.2 Panel Attachment to Splines and Keys: Panels are attached to splines and keys with GRK Canada Ltd. 5⁵/₁₆-inch-diameter-by-4-inch-long (7.9 mm by 102 mm), RSS wood screws recognized in evaluation report ER-5883.

3.2.6 Splines: Splines, field-installed into the keyways of the vertical edges of the panels, shall be full panel height,

continuous 1.5 E grade TimberStrand described in Section 3.2.3 of this report. The Timberstrand LSL spline is installed with the strands parallel to the surface of the wall panel. The splines used in the $4\frac{3}{8}$ -inch-thick (111 mm) panels shall be $1\frac{3}{4}$ inches by $3\frac{1}{2}$ inches (44.5 by 89 mm). Splines used in the $7\frac{7}{8}$ -inch-thick (200 mm) panels shall be $3\frac{1}{2}$ inches by $3\frac{1}{2}$ inches (89 by 89 mm).

3.2.7 Keys: Keys, field-installed into the keyways in the horizontal edges of the panels, shall be 1.5 E grade Timberstrand LSL, described in Section 3.2.3. The Timberstrand LSL key is installed with the strands parallel to the bottom of the panel, or equivalently, perpendicular to the surface of the wall panel. Keys used in the $4\frac{3}{8}$ -inch-thick (111 mm) panels shall be $1\frac{3}{4}$ inches by $1\frac{3}{4}$ inches (44.5 by 44.5 mm). Keys used in the $7\frac{7}{8}$ -inch-thick (200 mm) panels shall be $3\frac{1}{2}$ inches by $1\frac{3}{4}$ inches (89 by 44.5 mm).

4.0 DESIGN AND INSTALLATION

4.1 Design:

The allowable wall panel heights and transverse loads for the panels are noted in Table 1. The allowable wall heights and combined transverse and axial loads on bearing walls consisting of the panels are noted in Table 2. For use as shear walls, the allowable racking shear loads are noted in Table 3. Conditions for use as a qualifying shear wall material include a minimum 4-foot-wide (1219 mm), 8-foot-high (2438 mm) panel with the strong axis of the OSB facings perpendicular to the wall height and with profile boards along each vertical edge of each 4-foot (1219 mm) panel width and a minimum shearwall height-to-width ratio of 1:1. Also, the racking shear values noted in Table 3 shall be limited to structures located in Seismic Design Categories A, B and C.

4.2 Installation:

4.2.1 General: The panels shall be field-joined together by means of a spline installed into the keyways in the vertical edges of both panels. The panels shall be attached to the splines with the adhesive described in Section 3.2.4.2, and screws described in Section 3.2.5. A minimum $\frac{3}{8}$ -inch-diameter (9.5 mm) continuous bead of adhesive shall be applied to all three surfaces of each keyway. The screws shall be spaced 12 inches (25.4 mm) on center on both sides of the joint and both faces of the panels. See Figure 3.

For installations on concrete foundations, a pressure-preservative-treated 2-by sill plate shall be installed beneath the key, described in Section 3.2.7, attached to the foundation in accordance with the applicable code. The sill plate shall have a width equal to or greater than the total panel thickness, providing full bearing support for all components of the panel. The panels shall be placed over the key and 2-by sill plate with the key in the keyway in the bottom of the panels. The panels shall be attached to the key with the adhesive described in Section 3.2.4.2 and screws described in Section 3.2.5.2. See Figure 4.

Wall panels subject to wind or seismic forces and/or supporting roof and/or floor framing shall be designed to provide a continuous load path from the horizontal roof or floor deck to the foundation. The design must consider the panel fasteners and wood blocking between rafters and floor joists in order to provide a continuous load path capable of transferring the design shear forces between the horizontal diaphragms and the panels and between the panels and the foundation.

The orientation of the panels' OSB facings shall be consistent with Tables 1 and 2, as applicable, and as described in Section 3.2.

The panels are permitted to be prepared to include provisions for plumbing and waste lines extending, at a right

angle, through the wall panel, but not vertically or horizontally within the panel core.

Wall openings are permitted in accordance with Section 4.2.4 of this report.

4.2.2 Exterior Wall Covering: Wall panels shall be covered with an approved exterior wall covering, and a weather-resistive barrier as required by IBC Section 1404.2 or IRC Section R703.2. Where portland cement plaster is used, compliance with IBC Sections 2510 and 2512 or IRC Section R703.6 is required.

4.2.3 Interior Finish: Minimum $\frac{1}{2}$ -inch-thick (12.7 mm) gypsum wallboard complying with ASTM C36 shall be installed on the interior face of the wall panels. The gypsum wallboard shall be installed on the wall panels with the longitudinal edge of the wallboard oriented perpendicular to the wall panel joints. The gypsum wallboard shall be attached to the OSB facings of the sandwich panels with No. 6 by $1\frac{5}{8}$ -inch-long (38 mm) buglehead gypsum wallboard screws complying with ASTM C 1002, spaced 8 inches (203 mm) on center along the gypsum wallboard edge and ends, and spaced 12 inches (305 mm) on center in the field of the wallboard.

4.2.4 Wall Openings: Wall openings for doors and windows shall be framed with conventional construction materials, and designed, in accordance with the applicable code.

4.3 Special Inspection:

Special inspection of the application of the adhesive to the keyways as noted in Section 4.2.1 of this report, and for site-built panel assemblies, is required in accordance with Section 1704.6 of the IBC. Special inspection is not required for site-built panel assemblies used in Group R-3 occupancies as defined in Section 101.2 of the IBC or one- and two-family dwellings constructed in accordance with the IRC.

4.4 Fire-resistance Rated, Limited Load-bearing, Wall Assemblies:

The $4\frac{3}{8}$ -inch-thick (111 mm) wall panel, with a maximum applied axial load of 760 pounds per lineal foot (11,081 N/m) and a maximum wall height of 8 feet (2438 mm), is assigned a one-hour fire-resistance rating for load-bearing walls. The $7\frac{7}{8}$ -inch-thick (200 mm) panel with a maximum applied axial load of 1,500 pounds per lineal foot (21 900 mm) and a maximum wall height of 10 feet (3048 mm), is assigned a two-hour fire-resistance rating for load-bearing walls. The panels shall be constructed with one layer of $\frac{1}{2}$ -inch (12.7 mm) regular gypsum wallboard installed on each face of the wall as described in Section 4.2.3. If the panel occurs at an exterior wall, the gypsum board shall be gypsum sheathing complying with ASTM C 79, and the exterior wall covering and weather resistive barrier required in Section 4.2.2 shall be installed over the gypsum sheathing. The wall panels shall be installed as described in Section 4.2.1.

5.0 CONDITIONS OF USE

The Agriboard Panel Building System described in this report complies with, or is a suitable alternative to what is specified in, those codes listed in Section 1.0 of this report, subject to the following conditions:

- 5.1** The allowable panel spans and allowable loads shall be limited to the values in this report.
- 5.2** All construction documents specifying the building panels described in this report shall comply with the design limitations of this report. Drawings and design details demonstrating that the Agriboard Panel Building System complies with this report shall be submitted to the code official at the time of permit application. The drawings and design details shall be prepared by a

registered design professional where required by the statutes of the jurisdiction in which the project is to be constructed.

- 5.3** Calculations and details for the connection and attachment of the Agriboard Panel System to the supporting structural elements of the building, and the design of framing around openings in accordance with Section 4.2.4, shall be prepared by a registered design professional, when required by the statutes of the jurisdiction in which the panels are constructed, and submitted to the code official for approval.
- 5.4** The panels shall be limited to use in Type V construction and to Seismic Design Categories A, B and C.
- 5.5** The panels and their attachments shall be inspected and approved by the building official prior to covering with approved wall coverings.
- 5.6** Special Inspection shall be provided in accordance with Section 4.3 of this report.
- 5.7** The panels are manufactured at the Agriboard Industries facility in Electra, Texas, under a quality

control program with inspections by Omega Point Laboratories (AA-657).

6.0 EVIDENCE SUBMITTED

- 6.1** Data in accordance with the ICC-ES Acceptance Criteria for Sandwich Panels (AC04), dated February 2004, and reports of corrosiveness, fungi resistance, moisture vapor absorption, odor emissions, smoldering combustion, flame-spread, smoke-density and fire endurance tests.
- 6.2** A quality control manual.
- 6.3** Manufacturer's published installation instructions.

7.0 IDENTIFICATION

Each Agriboard panel shall have a label bearing the Agriboard Industries name and address, the thickness and density of the panel core, the evaluation report number (ESR-1582) and the name or logo of the inspection agency (Omega Point Laboratories).

TABLE 1—ALLOWABLE TRANSVERSE LOADS^{1,2,3}

PANEL THICKNESS (inches)	PANEL HEIGHT ^{4,5} (feet)	MAXIMUM SPACING OF PROFILE BOARDS (ft-in)	ALLOWABLE TRANSVERSE LOAD (psf)				
			Mid-height Deflection Limits				
			L/120	L/240	L/360	L/600	L/720
4 ³ / ₈	8	4 - 1 ³ / ₄	59	34	24	14	11
		8 - 1 ³ / ₄	44	27	19	11	9
		>8 - 1 ³ / ₄	28	19	14	9	7
7 ⁷ / ₈	8	4 - 3 ¹ / ₂	165	152	98	53	42
		8 - 3 ¹ / ₂	115	96	62	35	29
		>8 - 3 ¹ / ₂	60	35	24	16	14
	10	4 - 3 ¹ / ₂	150	136	88	48	38
		8 - 3 ¹ / ₂	105	87	57	32	26
	12	4 - 3 ¹ / ₂	134	120	78	42	34
		8 - 3 ¹ / ₂	96	78	51	29	24
	14	4 - 3 ¹ / ₂	119	104	67	37	30
		8 - 3 ¹ / ₂	87	69	45	26	21
	16	4 - 3 ¹ / ₂	104	88	57	32	25
		8 - 3 ¹ / ₂	78	60	39	23	18
	18	4 - 3 ¹ / ₂	88	73	47	26	21
		8 - 3 ¹ / ₂	69	51	33	19	16
	20	4 - 3 ¹ / ₂	73	57	37	21	17
		8 - 3 ¹ / ₂	60	43	28	16	13
	22	4 - 3 ¹ / ₂	57	41	26	15	12
		8 - 3 ¹ / ₂	51	34	22	13	11
	24	4 - 3 ¹ / ₂	42	25	16	10	8
		8 - 3 ¹ / ₂	42	25	16	10	8

For SI: 1 inch = 25.4 mm, 1 foot = 304.8 mm, 1 psf = 47.9 Pa.

¹The panel is fabricated in 4-foot-wide sections. For panels that are 8 feet high, the core shall be oriented with the 4-foot dimension horizontal. For panels exceeding 8 feet in height, the panel width is 8 feet, with the panel core oriented with the 4-foot dimension vertical.

²All heights shown are simple span.

³Allowable loads are for panels with no openings. The design of panels with openings is beyond the scope of this report and must be engineered.

⁴The panel heights are the wall heights, with the panels continuous for the specified height.

⁵For panel heights greater than 8 feet, intermediate profile boards are centered between the panel edges.

TABLE 2—ALLOWABLE AXIAL COMPRESSION LOADS (plf) ON BEARING WALLS WITH TRANSVERSE LOADS^{1,2,3,4}

PANEL THICKNESS (inches)	PANEL HEIGHT ⁷ (feet)	MAXIMUM SPACING OF PROFILE BOARDS ⁸ (ft-in)	TRANSVERSE LOAD (psf)									
			5	10	15	20	25	30	35	40	45	50
4 ^{3/8} ⁵	8	4 - 1 ^{3/4}	1712	1565	1418	1272	1125	978	831	684	537	391
		8 - 1 ^{3/4}	1514	1314	1113	913	713	513	312	112	—	—
		>8 - 1 ^{3/4}	1287	1009	732	455	177	—	—	—	—	—
7 ^{7/8} ⁶	8	4 - 3 ^{1/2}	1946	1885	1825	1764	1704	1643	1583	1523	1462	1402
		8 - 3 ^{1/2}	1616	1543	1471	1398	1325	1252	1179	1107	1034	961
		>8 - 3 ^{1/2}	1241	1132	1024	915	807	698	590	481	373	265
	10	4 - 3 ^{1/2}	2355	2270	2184	2098	2013	1927	1841	1756	1670	1585
		8 - 3 ^{1/2}	2040	1949	1857	1766	1674	1583	1492	1400	1309	1217
	12	4 - 3 ^{1/2}	2355	2237	2118	1999	1880	1761	1642	1523	1404	1285
		8 - 3 ^{1/2}	2086	2006	1926	1847	1767	1687	1608	1528	1448	1369
	14	4 - 3 ^{1/2}	2355	2204	2052	1900	1747	1595	1443	1291	1138	986
		8 - 3 ^{1/2}	2131	1975	1818	1662	1506	1349	1193	1036	880	724
	16	4 - 3 ^{1/2}	2355	2171	1985	1800	1614	1429	1243	1058	872	687
		8 - 3 ^{1/2}	2177	1988	1799	1610	1421	1232	1044	855	666	477
	18	4 - 3 ^{1/2}	2355	2138	1919	1701	1482	1263	1044	825	607	388
		8 - 3 ^{1/2}	2222	2001	1779	1558	1337	1115	894	673	452	230
	20	4 - 3 ^{1/2}	2355	2105	1853	1601	1349	1097	845	593	341	89
		8 - 3 ^{1/2}	2267	2014	1760	1506	1252	999	745	491	237	—
	22	4 - 3 ^{1/2}	2355	2072	1787	1502	1216	931	645	360	75	—
		8 - 3 ^{1/2}	2313	2027	1740	1454	1168	882	596	309	23	—
	24	4 - 3 ^{1/2}	2355	2040	1721	1402	1084	765	446	127	—	—
8 - 3 ^{1/2}		2358	2040	1721	1402	1084	765	446	127	—	—	

For SI: 1 inch = 25.4 mm, 1 foot = 304.8 mm, 1 plf = 14.6 N/m, 1 psf = 47.9 Pa.

¹Axial load may be applied by roof or floor joists spaced 24 inches on center, maximum. The transverse load shall not exceed the allowable transverse load for the applicable deflection limit noted in Table 1.

²All heights shown are simple span.

³No increase is permitted to the tabulated values for wind or seismic loading conditions.

⁴Allowable loads are for panels with no openings. The design of panels with openings is beyond the scope of this report and must be engineered.

⁵Bearing area of framing members shall be equal to or greater than 6.5 square inches.

⁶Bearing area of framing members shall be equal to or greater than 11.8 square inches.

⁷The panel heights are the wall heights, with the panel continuous for the specified heights.

⁸For panel heights greater than 8 feet, intermediate profile boards are centered between panel edges.

TABLE 3—ALLOWABLE SHEARWALL RACKING LOADS¹ (plf)

PANEL THICKNESS (inches)	ALLOWABLE RACKING LOAD (plf)
4 ^{3/8} 7 ^{7/8}	5751115

For SI: 1 inch = 25.4 mm, 1 foot = 304.8 mm, 1 plf = 14.6 N/m.

¹Maximum panel height-to-width ratio is 1:1.

AGRIBOARD INDUSTRIES

4" PANEL KEYWAY GEOMETRY

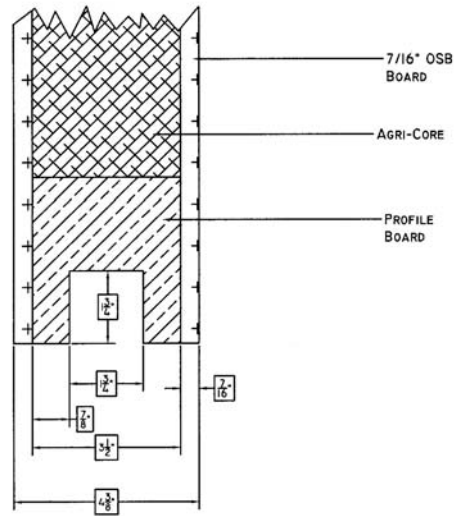

FIGURE 1

AGRIBOARD INDUSTRIES

8" PANEL KEYWAY GEOMETRY

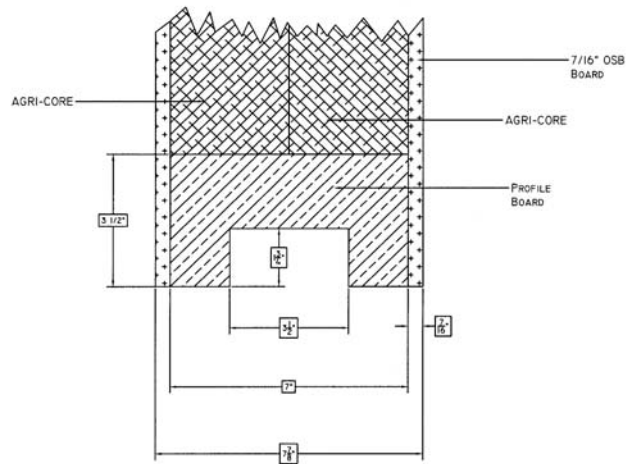

FIGURE 2

WALL TO WALL KEYWAY CONNECTION

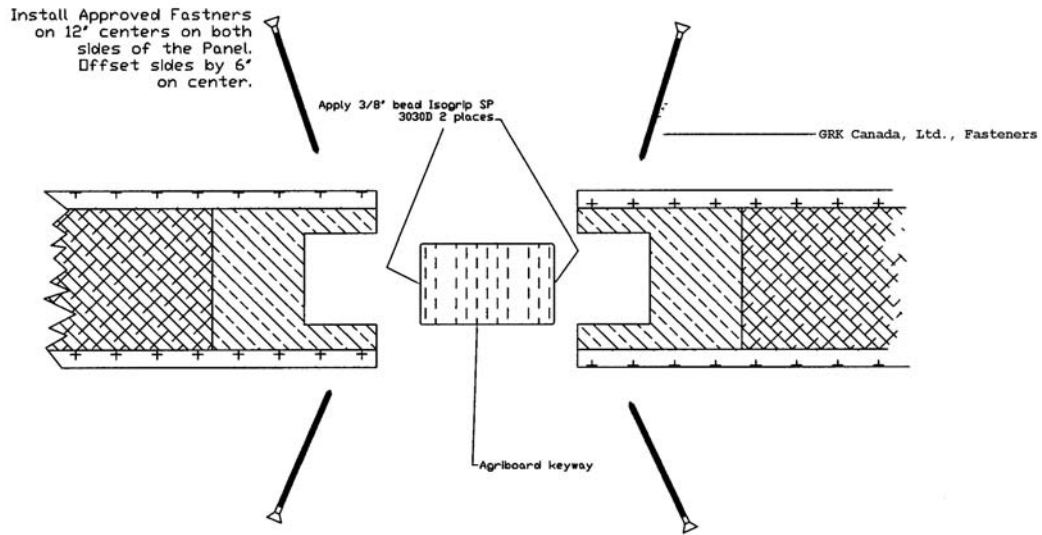

FIGURE 3